

All-in-one Heat Pump Water Heater

Installation and owner's manual

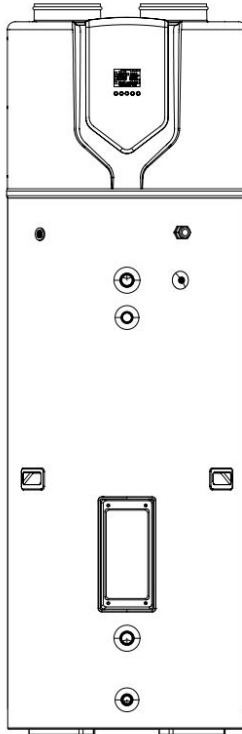

**Thank you very much for purchasing our product.
Before using your unit, please read this manual carefully
and keep it for future reference.**

Content

1. Safety information	3
2. Preparations of installation	5
2.1 Transport	5
2.2 Packing list	6
2.3 Installation site requirements	7
2.4 Maintenance space requirements	8
2.5 Unit dimension	8
2.6 Part names:	9
2.7 Specification	10
3. Installations	11
3.1 Water system piping diagram	11
3.2 Connection of duct	14
3.3 Condensate water drainage	16
3.4 Electric connection	16
3.5 Installation checking	19
4. Trial-running	20
4.1 Water affusion before operation	20
4.2 Water emptying before cleaning	21
4.3 Trial-running	21
5. Operation	22
6. Device Networking	41
7. App Operation	43
7.1 Power ON/OFF	43
7.2 DHW Temperature Setting	43
7.3 Electric heater quick heating mode	44
7.4 Timer setting	44
7.5 Fault Query	45
8. Maintenance	46
8.1 Maintenance	46
8.2 How to change the anode rod	46
8.3 Recommended regular maintenance table	47

WARNING



The heat pump unit is required reliable earthing connection before usage. Otherwise it might cause death or injury.





If you cannot confirm that your house power supply is earthed well, please do not install the unit before carefully check it. Please have a qualified person to check the reliable earthing connection and install the unit.

Examples of a qualified person include: Licensed plumbers, Authorized electric company personnel, and Authorized service personnel.

1.Safety information

Please carefully read thoroughly all of the instructions before installing or operating the unit. Following safety symbols are very important, please carefully read and always obey all safety symbols.

 CAUTION	It maybe cause that people is injured if not obey the instructions.
 WARNING	It maybe cause that people is seriously injured or killed if not obey the instructions.
 DANGER	It maybe cause that people is seriously injured or killed immediately if not obey the instructions.



WARNING

- The unit must be earthed effectively and reliably.
- A residual current operated circuit-breaker (RCCB) must be installed adjacent to the power supply.
- Do not remove, cover or deface any permanent instructions, labels or the data labels from either the outside of the unit or inside of unit panels.
- Only the qualified person can perform the installation of this unit in accordance with local national regulations and this installation manual. Improper installation may result in water leakage, electric shock or fire.
- Only the qualified person can relocate, repair and maintain the unit. Improper installation and repairing may result in water leakage, electric shock or fire.
- Electric connection work should obey the instructions of local power company, local electric utility and this manual.
- Never use the wire and fuse with wrong rated current, otherwise unit may breakdown and cause fire furthermore.
- Do not insert fingers, rods or other objects into the air inlet or outlet. When the fan is rotating at high speed, it will cause injury.
- Never use a flammable spray such as hair spray, lacquer paint near the unit, because it may cause a fire.
- The heat pump unit is not intended for use by persons (including children) with reduced physical, sensory or mental capabilities, or lack of experience and knowledge, unless they have been given supervision or instruction concerning use of the unit by a person responsible for their safety. Children should be supervised to ensure that they do not play with the unit.
- Once the power supply cord is damaged, it must be replaced by service agent or the manufacturer or a similarly qualified person.



- Do not dispose this unit as unsorted municipal waste. Collection of such waste separately for special treatment is necessary.
- Do not dispose of electrical appliances as unsorted municipal waste, use separate collection facilities. Please contact local government for information regarding the collection systems available.
- If electrical appliances are disposed of the landfills or dumps, hazardous substances can leak into the groundwater and get into the food chain, damaging your health and well-being.



CAUTION

- The ground wire's pole of socket must be grounded well, make sure that power supply socket and plug are enough dry and connected well.
- To check the power supply socket and plug are qualified .
 - Step 1: Turn on the power supply.
 - Step 2: Keep the unit running for a half hour.
 - Step 3: Turn off the power supply and plug out.
 - Step 4: Check whether the socket and plug is hot or not.
- Before cleaning, be sure to stop the operation and turn the breaker off or pull out the power supply plug. Otherwise, an electric shock and injury may be caused.
- Produced hot water temperature can reach over 50°C. It can cause severe burns instantly or death form scalds. Children, disabled and elderly persons are at highest risk of being scalded. Feel water is necessary before bathing or showering. So, water temperature limiting valves are recommended.



- Do not operate the unit with a wet hand; Otherwise, an electric shock may be caused.
- The installation height of power supply should be over 1.8m. If there is any water spattered, separate the power supply from water.
- It is normal if some water drops from the hole of PTR valve during operation. But if there is a great amount of water, call the service agent for instruction.
- After a long term use, check the unit base and fittings. If damaged, the unit may sink and result in injury.
- Arrange the drain pipe to ensure smooth draining. Improper drainage work may cause wetting of the building, furniture, etc.
- Do not touch the inner parts of the controller. Do not remove the front panel. Some parts inside are dangerous to touch, otherwise the unit malfunction may be caused.
- Do not turn off the power supply. System will stop or restart heating automatically during the standby mode. A continuous power supply for the unit is necessary, except service and maintenance.
- If the unit has not been used for a long period of time (2 weeks or more), hydrogen gas will be produced in the water piping system.

-
- Hydrogen gas is extremely flammable. To reduce the risk of injury under these conditions, it is recommended that open the hot water tap for several minutes at the kitchen sink before using any electrical appliance connected to the hot water system. When hydrogen is present, there will probably be an unusual sound such as air escaping through the pipe as the water begins to flow. There should be no smoking or open flame near the tap at the time it is open.
-

2.Preparations of installation

2.1 Transport

- In order to avoid scratch or deformation of the unit surface, please use guard boards to contacting surface.
- No contact of fingers and other things with the vanes.
- Do not incline the unit more than 45° to move. When install the unit, please keep the unit vertical.

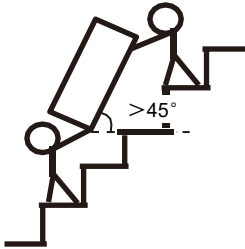

Gradient limit should be more than 45°

- Because the unit is very heavy, it needs two or more persons to carry the unit. And otherwise, it might cause injury and damage of the unit.

2.2 Packing list



Item	Quantity	Item	Quantity
Heat pump water heater	1	Quick insertion valve (Exhaust air in water cycle)	1
Installation & User manual	1	Quick union (Connect with The manual exhaust outlet located above tank)	1
Relief valve (0.7MPa)	1	PE tube (1.2m)	1
T/P valve (G3/4" connection, 0.8MPa)	1	Drain outlet pipe cap cover	1
Male-thread Straight tube with outside (Connect with Relief valve of DHW tank)	1	PG Connector	1

2.3 Installation site requirements

- Enough space for the unit installation and maintenance should be preserved.
- The surrounding of air inlet and outlet should be free from obstacles and strong wind.
- The base surface should be flat, surface should be inclined no more than 2° and able to bear the weight of the unit and suitable for installing the unit without increasing noise or vibration.
- The operation noise and air flow expelled shall not affect neighbors.
- No flammable gas is leaked nearby.
- It is convenient for piping and wiring.
- If it is installed in indoor space, it might cause indoor temperature decreased or noise. Please take preventive measures for this.
- If the unit has to be installed on a metal part of the building, make sure that the reliable electric insulation which should meet the relevant local electric standard.



CAUTION

- The ambient temperature must also be considered when installing this unit, in heat pump mode the ambient temperature must be above -5°C and below 43°C. If the ambient temperature falls outside these upper and lower limits, the electrical elements will be activated to meet the hot water demand and the heat pump does not operate.
- The unit should be located in an area not subject to freezing temperatures. The unit located in unconditioned space (garages, basements, etc.) may require the water piping condensate piping, and drain piping to be insulated to shelter against freezing.
- When installing the unit in the following places, it may lead to the malfunction of the unit: (If it is inevitable, please consult with the unit supplier.)
 - The place contains mineral oils, for example, lubricant of cutting machines.
 - Seaside where the air contains salt.
 - Hot spring area where there are some corrosive gases like sulfide gas.
 - Factories where the high voltage power fluctuates seriously.
 - Inside a car or cabin.
 - The place with direct sunlight and other heat supplies. If it is not avoid, please install a covering or take other measurement.
 - Place where is contained by oil permeates like kitchen.
 - Strong electromagnetic wave surrounding.
 - The place filling with danger or flammable gases or materials.
 - The place filling with acid or alkali gases.



WARNING

- The unit must be securely installed; otherwise some noise and shaking may be produced.
 - Confirm that there is no any obstacle around the unit.
 - If there is strong wind like seashore, please fix the unit in the place where is protected from the wind.
-

2.4 Maintenance space requirements

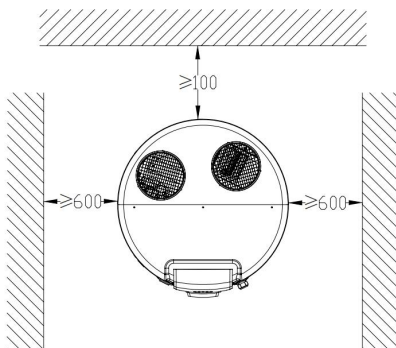

If the unit is installed in an enclosed space:

The heat pump unit must be placed in a space which is more than 15m,³ and must have unrestricted air flow.

For example, the space of the installed unit is one room with 2.5m height ceiling and with 3m length by 2m width.

2.5 Unit dimension

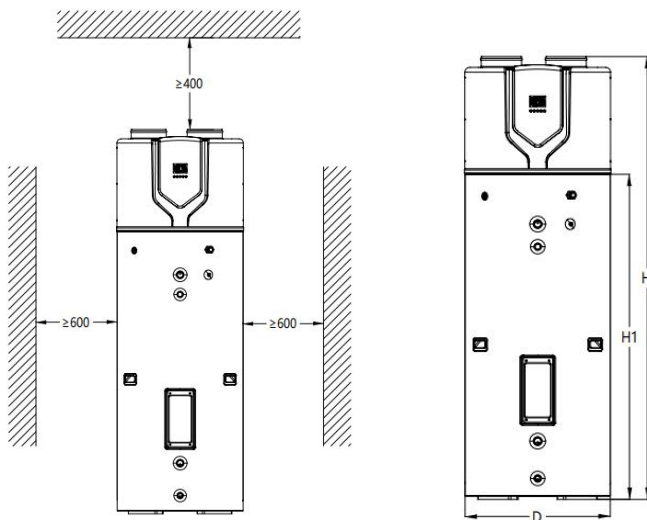

Model	200L	300L
Diameter φ D (mm)	640	640
High H (mm)	1565	1960

2.6 Part names:

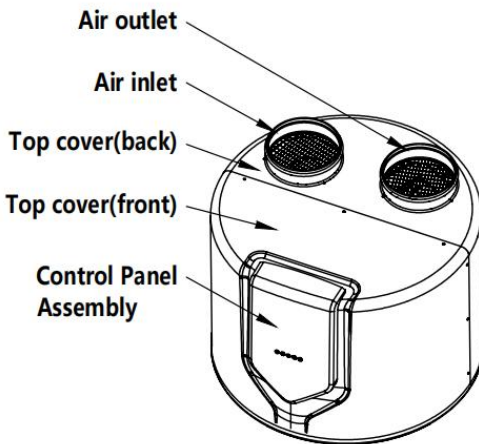
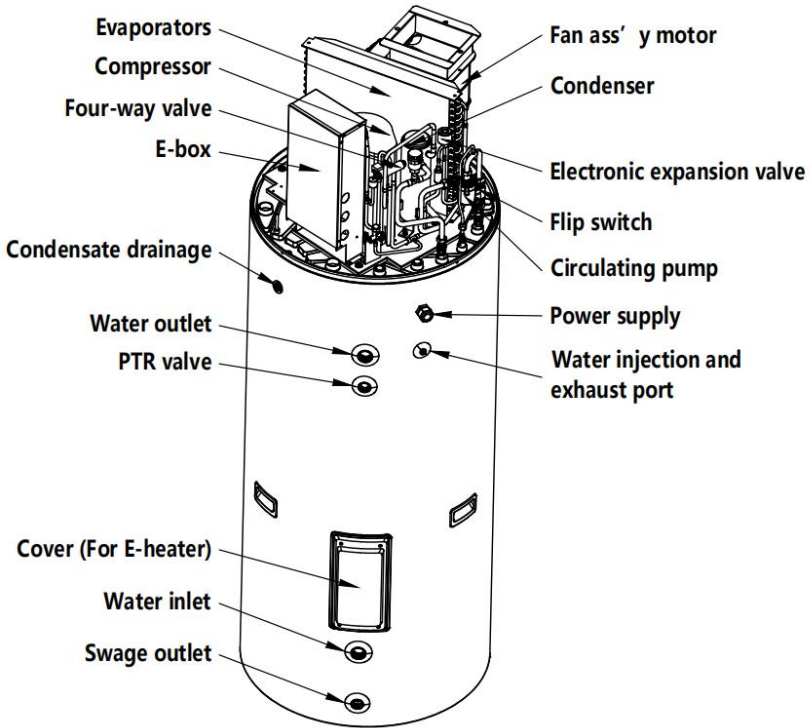

2.7 Specification

Domestic Hot Water Heat Pump		
Model name	J12HW200V2	J12HW300V2
Power supply	220-240V/~50Hz	220-240V/~50Hz
Capacity	1.5kW	1.5 kW
Power input	0.4 kW	0.4 kW
COP	3.75	3.75
Max. power input	3.58 kW	3.58 kW
Max. current	16 A	16 A
Refrigerant type/Charge	R290/150 g	R290/150 g
ELE. power input	3 kW	3 kW
Max. outlet water temp.	75 °C	75 °C
Max. operating pressure (high/low side)	2.8 / 1.0MPa	2.8 / 1.0MPa
Rated water pressure	0.7MPa	0.7MPa
Storage tank volume	200 L	300 L
Water piping connections	G1'	G1'
Hot water pressure relief valve	0.7Mpa	0.7Mpa
Sound power level	50B(A)	50dB(A)
Net dimensions(L×W×H)	Φ640*1565 mm	Φ640*1960 mm
Running temp. range	-7~45 °C	-7~45 °C
Net weight	72 kg	84 kg
Unit protection class (with air inlet duct)	IPX1	IPX1
Capacity and power input based on the following conditions: Ambient temperature 20 °C, Heat source temperature 7 °C/6 °C, water temperature from 10 °C to 53 °C.		
Hermetically sealed system, leak tested Contains fluorinated greenhouse gasses covered by the kyoto protocol		

3. Installations

The circulating air flow of every unit should be more than 350m³/h. Please make sure that there is enough installation space.

3.1 Water system piping diagram

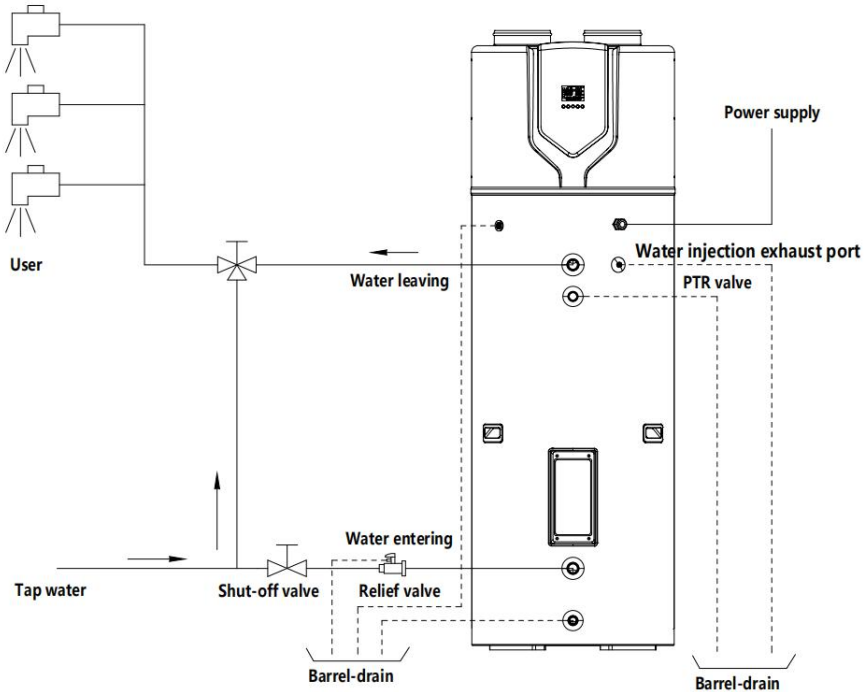

Notes:

- 1) The PTR valve is only available for some models.
- 2) The temperature limiting valve is required on the hot water usage terminal.
- 3) The relief valve as accessory must be connected. Drainage pipe connected with the relief valve should be connected with atmosphere.
- 4) After all the pipes installed turn on the cold water inlet and hot water outlet to fill the tank. When there is water normally following out from water outlet, the tank is full. Turn off all valves and check all pipes. If any leakage, please repair.



CAUTION

- Water piping system as the above figure. When install the unit at a place where outside temperature below freezing point, the insulation must be provided for all hydraulic components.
- The handle of PTR valve should be pulled out once per half a year to confirm that there is no jam of the valve. At the same time, please take care of hot water from the valve and burning.
- The outlet drain pipe should be insulated well in order to prevent water which is kept inside the pipe from freezing in cold conditions.



WARNING

It will cause explosion and injury, if do not comply with the following instruction:

- Do not dismantle the PTR valve.
 - Do not block off the outlet drain pipe.
-

The specifications of water inlet and outlet pipes as following:

- Internal thread (G1').
- Pipes must be heat-insulated well.
- Installation of the pipe of PTR valve's thread is RC3/4' (external thread). When finish the installation, it must be confirmed that the outlet drain pipe of the PTR valve is exposed in the air.
- The relief valve is necessary. It can prevent the supplied water from flowing backwards.
- Connection dimensions as shown in the figure below.

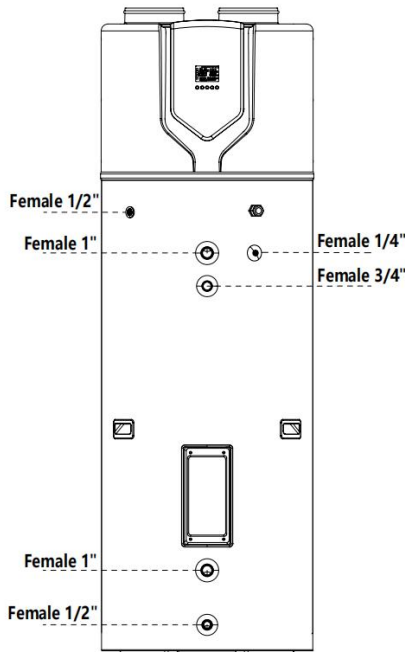

-
- After water system piping work, turn on the cold water inlet valve and hot water outlet valve and start effusing the tank. When water flow smoothly out from tap of water outlet, it means the tank is full. Please turn off all valves and check pipeline to make sure there is without any leakage.
 - If the inlet water pressure is less than 0.15MPa, a pump should be installed at the water inlet pipe.
 - For the safety usage of water tank at the condition of water supply pressure higher than 0.65MPa, a reducing valve should be installed at the water inlet pipe.
 - Condensate may be leaked from the unit if condensate drainage pipe is blocked or it operates in high humidity environment, a drainage pan is recommended as shown as the following figure:

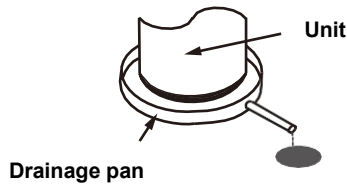

3.2 Connection of duct

- ◆ When the ducts of both air inlet and outlet, $a+b+c+d \leq 8m$.

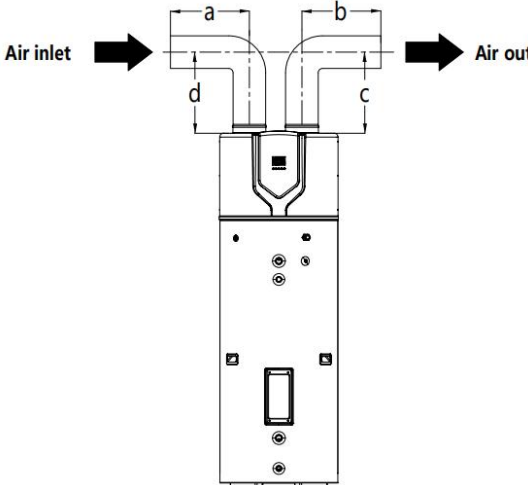

- ◆ When the duct only air inlet, $b+c \leq 8m$. (fig1)
- ◆ When the duct only air outlet, $a+d \leq 8m$. (fig2)

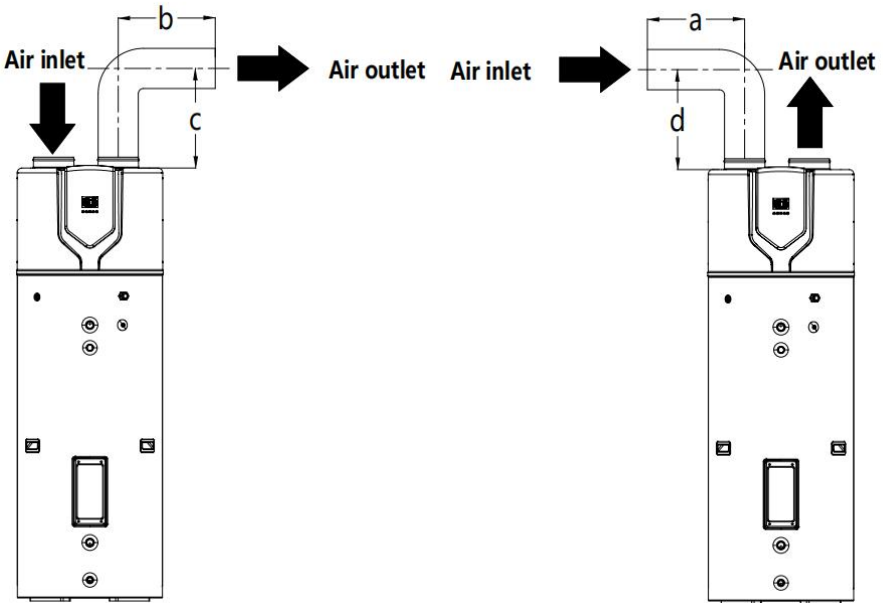

(fig1)

(fig2)

- ◆ The duct specifications:

Duct type		Round duct
Dimensions		Φ180mm
Pressure drop	Straight	≤2Pa/m
	Bent	≤2Pa/m
Bent quantity		≤3

NOTES

- When the air duct is connected, the unit capacity will be decreased because of the decreased air flow by the resistance of the duct.
- If the duct is connected, the duct total length should be not more than 8m, or the maximum static pressure should be within 15Pa. By the way, the quantity of bending should be not more than 3.
- When the unit with duct operates, condensate water will be generated around the out surface of the duct. So please wrap the thermal insulated layer around the duct.
- The unit should be installed in the indoor space, and it is not allow installing the unit at the rainy place.



WARNING

- Please avoid the water entering to the internal of the unit because the water will cause the component inside the unit damage or physical danger.
- If the unit is connected with duct which is reaching to outdoor, it is necessary to supply a reliable water-resistant measure on the unit to prevent water dropping from outside to internal of the unit.

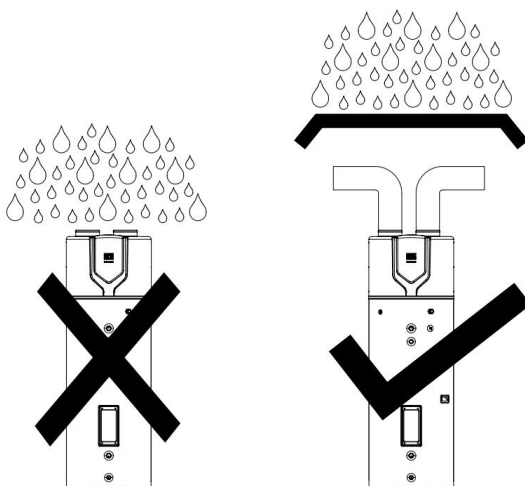

3.3 Condensate water drainage

To smoothly drain the condensate water, please install the unit at a horizontal floor. Recommending the inclination angle of the unit to the ground should be no more than 2°

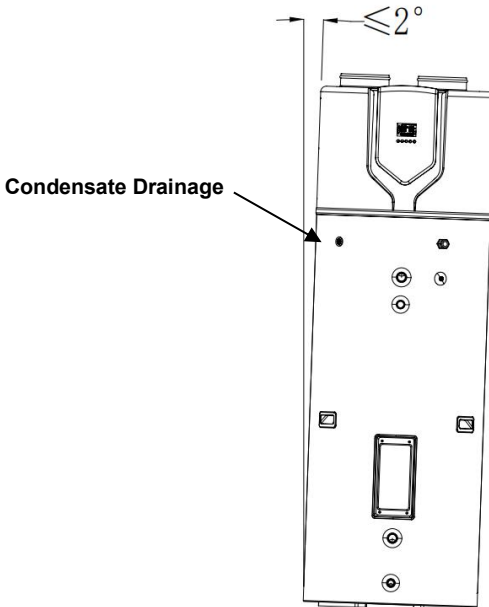

3.4 Electric connection



CAUTION

- The power supply should be an independent circuit with rated voltage.
- Power supply circuit should be earthed effectively. The wiring must be performed by professional technicians in accordance with national wiring regulations and the unit circuit diagram.
- An all-pole disconnection device which has at least 3mm separation distance in all poles and a residual current device (RCD) with the rating of above 10mA shall be incorporated in the fixed wiring according to the national rules.
- Set the electric leakage protector according to the relevant electric technical standards of the state.
- The power supply cord and signal cord shall be laid out neatly and properly without mutual interference or contacting the connection pipes.
- After wires connection, check it again and make sure the correctness before power on.

3.4.1 Electric wiring diagram

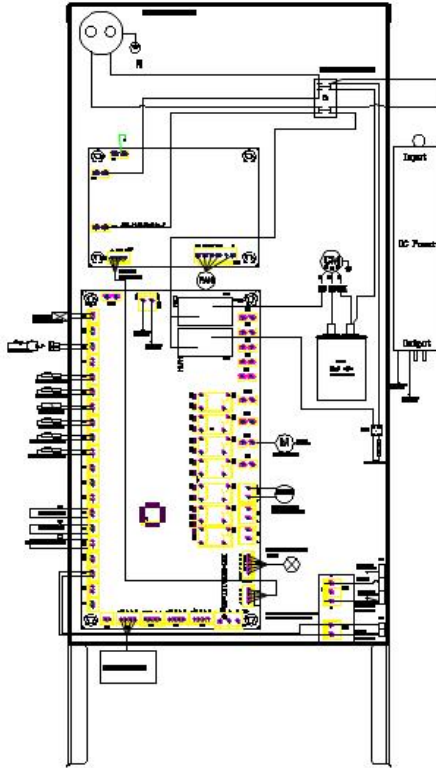

3.4.2 Specifications of power supply

Power supply	220-240V~, 1Ph, 50Hz
Min. diameter of power supply cord	2.5mm ²
Earth cord	2.5mm ²
Manual switch capacity / Fuse	25A / 25A
Leakage current circuit breaker	30mA, ≤0.1Sec

- Please choose the power supply cord according to the above table, and it should comply with local electric standard.
- The power supply cord model, recommended power supply cord is H05RN-F/H05RR-F.



WARNING

The unit must be installed with a Leakage current circuit breaker near the power supply and must be effectively earthed.

3.4.3 Remote control connection



2pin Terminal	Passive linkage
3pin Terminal	Strong electric interlocking signal(L S N) Note:Double wires is N

3.5 Installation checking

3.5.1 Location checking

- The flooring beneath the water heater must be able to support the weight of the unit when filled with water.
- Located indoors (such as a basement or garage) and in a vertical position. Sheltered from the freezing temperatures.
- Provisions made to shelter the area from water damage. Metal drain pan installed and piped to an adequate drain.
- Sufficient space to service the water heater.
- Sufficient air for the heat pump to function, the water heater must be located in a space which is more than 15m³, and must have unrestricted air flow.



NOTES

For optimal efficiency and service ability, the following clearances should be maintained: 800mm on the air inlet side, 800mm on the air outlet side, 100mm in the back, and 600mm in the front.

- The unit cannot be placed into any type of closet or small enclosure.
- The site location must be free from any corrosive elements in the atmosphere such as sulfur, fluorine and chlorine. These elements are found in aerosol sprays, detergents, bleaches, cleaning solvents, air fresheners, paint and varnish removers, refrigerants and many other commercial and household products. In addition excessive dust and lint may affect the operation of the unit and require more frequent cleaning.
- The ambient air temperature must be above -5°C and below 43°C. If the ambient air temperature falls outside these upper and lower limits the electrical elements will be activated to meet the hot water demand.

3.5.2 Checking of the water system piping

- PTR valve (Temperature and pressure relief valve) properly installed with a discharge pipe run to an adequate drain and sheltered from freezing.
- All piping properly installed and free of leaks.
- Unit completely filled with water.
- Water temperature limit valve or mixer tap (Recommended) installed per manufacturer's instructions.

3.5.3 Checking of condensate drain pipe

- Must be located with access to an adequate drain or condensate pump.
- Condensate drain lines installed and piped to an adequate drain or condensate pump.

3.5.4 Checking of the electrical connections

- The water heater requires 220-240VAC for proper operation.
- Wiring size and connections comply with all local applicable codes and the requirements of this manual.
- Water heater and electrical supply are properly grounded.
- Proper overload fuse or circuit breaker protection installed.

3.5.5 Post installation review

- Understand how to use the controller to set the various parameters and functions.
-

- Understand the importance of routine inspection/maintenance of the condensate drain pan and lines. This is to help prevent any possible drain line blockage resulting in the condensate drain pan overflowing.
- **IMPORTANT:** Water coming from the plastic shroud is an indicator that both condensation drain lines may be blocked. Immediate action is required.
- To maintain optimal operation check, remove and clean the air filter.

4. Trial-running

4.1 Water affusion before operation

If the unit is used for the first time or used again after emptying the water tank, please make sure that the tank is full of water before turning on the power.

Method: please refer to the figure.

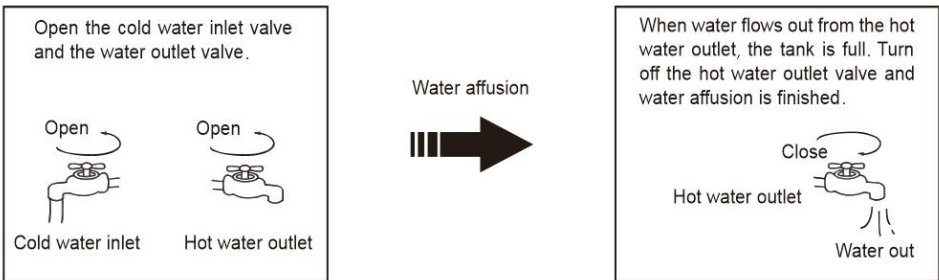

CAUTION

- Operation without water in water tank may result in the damage of the boost E-heater (electric heater). Due to such damage, manufacturer will not be responsible for any damages caused by this issue.
- After powered on, the display lights up. Users can operate the unit through the buttons under the display.

4.2 Water emptying before cleaning

If the unit needs cleaning, moving, etc, the water tank should be emptied.

Method: please refer to the figure.

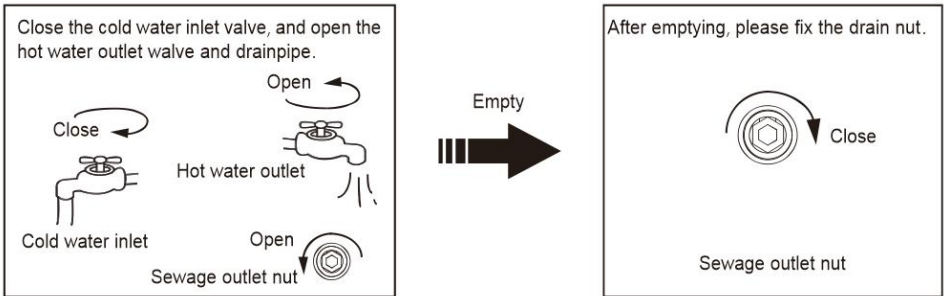

4.3 Trial-running

Checking list before commissioning:

- Correct installation of the system.
- Correct connection of the water/air and wiring.
- Condensate draining smoothly well insulation work for all hydraulic part.
- Correct power supply.
- No air in the water pipeline and all valves opened.
- Effective electric leakage protector installation.
- Sufficient inlet water pressure (Between 0.15MPa and 0.65Mpa).

5.Operation

5.1 Controller panel explanation

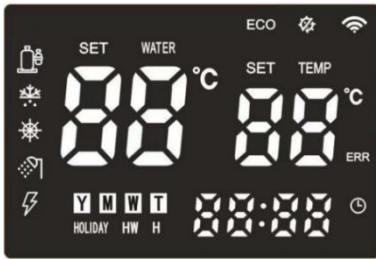



No.	Icon	Icon Name	Function		
1		On/Off	Click to turn on/off the heat pump unit.		
2		Setting button	Click to enter Function Menu.		
3		Timer button	Click to enter Timer Function Menu.		
4		Increase/up button	Click to Increase/up		
5		Decrease/down button	Click to Decrease/down		
No.	Icon	Function	No.	Icon	Function
1		Compressor icon	11		Year Month Week Time
2		Defrost mode icon	12		DHW timer function
3			13		
4		DHW mode icon	14		Weekday timer function
5			15		Disinfect timer function
6		Electric icon	16		Holiday Function
7		DHW setting temperature And DHW current temp.	17		Current time and Setting timer.
8		Heating setting temp. and Heating current temp. Especially "TEMP" will light up when heat pump under Room control mode but not light up in the Water control mode.	18		Timer icon
9		WIFI icon			
10		Error icon			

5.2 Lock/Unlock

	 <p>Press for 3 seconds when beep sound to unlock.</p>	<p>The screen will lock after 5 minutes of inactivity. Once locked, the interface becomes unresponsive, clicking any button causes the main screen to flicker but no settings can be adjusted even id during data adjusting.</p>
---	---	--

5.3 Turn on/off

	 <p>Press to turn on/off</p>	
---	---	---

5.4 Working mode selection

DHW mode





5.5 Set target temperature



In main interface press to enter target temperature setting.



	<p>DHW mode press  directly to set the target temperature.</p>
--	--

5.6 Version information







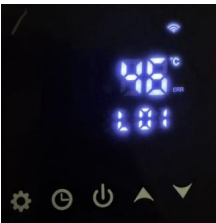

	<p>Press  3 seconds to check Unit Status information .</p>	
<p> + </p> <p>Press and hold for 3 seconds to view the Version No.</p>	 	<p>No compressor icon = Wire controller Version No.;</p> <p>With Compressor icon = Mainboard Version No.;</p> <p>Press  to switch Versions No.</p>

5.7 Function menu

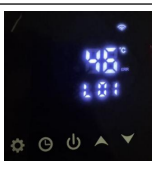
5.7.1. Unit Status information

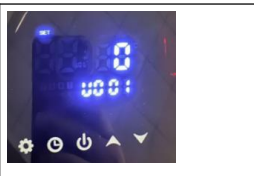









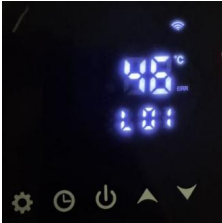

	<p>Press  for 3 seconds to check Unit Status information .</p>	
No.	Describe	Current Operating Data
L1	DHW tank temperature	°C
L2	Reserve	°C
L3	Reserve	°C
L4	Reserve	°C
L5	Reserve	°C
L6	Working Ambient Temperature	°C
L7	Outer Coil Temperature	°C
L8	Inlet water temperature	°C
L9	Outlet water temperature	°C
L10	Exhaust temperature	°C
L11	Return gas temperature	°C
L12	EEV opening	P
L13	Current fan speed	RPM
L14	DHW effect target temperature	°C
L15	Reserve	°C
L16	Reserve	°C

5.7.2. User parameters

	<p>Press  for 3 seconds to enter the interface of checking Unit Status information first.</p>	
	<p>And then press  again to check User parameters.</p>	
<p>If need to revise the parameter value, press  and the value flash. Press  to revise and press  to confirm.</p>		

No.	Describe	Default
U001	0 Water control,1-Room Control	0
U002	DHW target temperature(Range 20-70℃)	55
U003	Reserve	35
U004	Reserve	21
U005	DHW restart temperature(Range 1-10℃)	5
U006	Reserve	2
U007	Reserve	
U008	Reserve	2
U009	Reserve	
U010	Reserve	1
U011	Electric stops temperature(Range 1-5℃)	2
U012	Reserve	0
U013	Reserve	0
U014	Reserve	-25
U015	Reserve	-15
U016	Reserve	-2
U017	Reserve	5
U018	Reserve	15
U019	Reserve	45
U020	Reserve	42
U021	Reserve	38
U022	Reserve	35
U023	Reserve	30
U024	Sounds shut off(0 on,1 off)	1
U025	LED shut off(0 always on,1-10 minute)	0









5.7.3. Project parameters

	<p>Press  for 3 seconds to enter the interface of checking Unit Status information first.</p>	
<p>Press  for 3 seconds to enter the interface for password input.</p>		<p>Press  to change password (6666).</p> <p>Press  to change password location.</p> <p>Press  to confirm password.</p>
	<p>If need to revise the parameter value, press  and the value flash. Press  to revise and press  to confirm.</p>	

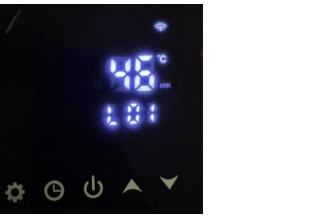





No.	Describe	Default
P001	Passive function(0 disable,1enable)	0
P002	SG ready function(0 disable,1enable)	0
P003	Target temperature rise to storage during EVU (0 disable,1enable)	0
P004	Reserve	
P005	Curing function(0 disable,1enable)	0
P006	Floor Curing Temperature Setting Stage 1(Range 25-35°C)	30
P007	Floor Curing Operation Duration Stage 1(Range 1-10days)	2
P008	Floor Curing Temperature Setting Stage 2Range 35-40°C)	38
P009	Floor Curing Operation Duration Stage 2(Range 1-10days)	5
P010	Floor Curing Temperature Setting Stage 3(Range 40-45°C)	42
P011	Floor Curing Operation Duration Stage 3(Range 1-10days)	10
P012	Room temperature compensation function(0 disable,1-30 minutes compensation one time)	0
P013	Shifting Priority(0 disable,1enable)	1

P014	Allowable Temp Drift in Heating(Range 3-10°C)	5
P015	Shifting Priority Starting Temp (Range -10-10°C)	10
P016	DHW Backup Heater for Shifting Priority(0disable,1enable)	0
P017	Sanitary Water Min. Working Hours(Range 20-180°C)	50
P018	Heating Max. Working Hours(Range 20-180°C)	30
P019	Emergency Operation base on HWTBH(0disable,1enable)	1
P020	Backup Heating Source f or Sanitary Hot Water (0disable,1enable)	1
P021	Priority for Backup Heating Sources (HWTBH) (0disable,1enable)	1
P022	Water Temperature Rise Reading Interval(Range 1- 120minutes)	25
P023	Emergency Operation base on HTBH(0disable,1enable)	1
P024	Release Integral for Backup heating (Range 10- 60°C*minutes)	45
P025	Control mode of circulation pump(0 always off,1-9 minutes off and run 9-1minutes,10 always run,when heating get the target temperature)	6
P026	Reserve	
P027	Reserve	1
P028	Secondary circulation pump run over temperature (Range 15-25°C)	20
P029	Secondary circulation pump stops under temperature (Range 15-25°C)	18
P030	Disinfect over temp setting: (Range60-75°C)	60
P031	Disinfect during time setting (Range 10-60minutes)	30
P032	Disinfect max time setting (Range 40-240minutes)	120

5.7.4. Reset default parameters

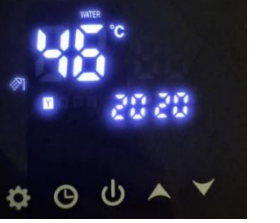
	<p>Press  for 3 seconds to enter the interface of checking Unit Status information first.</p>	
<p>Press  for 3 seconds to enter the interface for password input.</p>		<p>Press  to change Password (1134)</p> <p>Press  to change password location.</p> <p>Press  to confirm password.</p> <p>Until the buzzer sounds a long beep, finish all default parameters reset.</p>

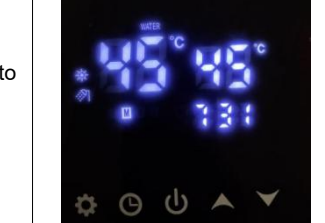
5.8 Time Setting

	<p>Press  for 3 seconds to set year.</p> <p>Press  to change year.</p>	
<p>Press  to set month first and press  to change month. (After month setting, same operation for day setting.)</p>		<p>After confirm the month and day, press  again to set time.</p> <p>Press  to change time.</p>

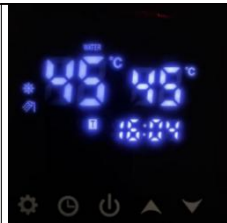

Press  to set year/month/day/time again if need.

Press  to confirm to back to main interface.

5.9 Set Timer function

5.9.1. DHW timer function



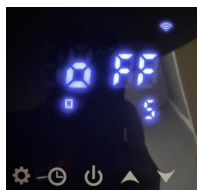

Press  some times until to show the "W" icon. Only display "W" can enter timer function setting.



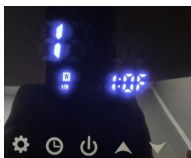

Long press  to set 1st period DHW timer's Monday.



Press  to enter the setting, and press  to set Monday ON/OFF.



If don't need to modify Monday default settings, press  to enter Tuesday setting.



Press  to enter the setting, and press  to set Tuesday ON/OFF.



If don't need to modify Tuesday default settings, press  to enter Wednesday setting.



Press  to enter the setting, and press  to set Wednesday ON/OFF.

If don't need to modify Wednesday default settings, press  to enter Thursday setting.



Press  to enter the setting, and press  to set Thursday ON/OFF.

If don't need to modify Thursday default settings, press  to enter Friday setting.





Press  to enter the setting, and press  to set Friday ON/OFF.

If don't need to modify Friday default settings, press  to enter Saturday setting.



Press  to enter the setting, and press  to set Saturday ON/OFF.



Press  to enter the setting, and press  to set Sunday ON/OFF.

If don't need to modify Saturday default settings, press  to enter Sunday setting.

If don't need to modify Monday-Sunday default settings, press  to set ON/OFF for 1st DHW timer.





1 ON = 1st DHW timer ON
1 OF = 1st DHW timer OFF

If don't need to modify 1st DHW timer ON/OFF default settings, press  to set 1st DHW timer start/stop time period.

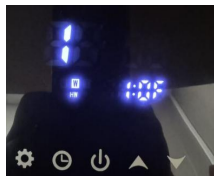

1o = 1st period timer ON Hour setting
1o = 1st period timer ON Minute setting
1F = 1st period timer OFF Hour setting
1F = 1st period timer OFF Minute setting







DHW has 4 periods timers. While setting the 1st timer, press  at switch to 2nd periods

through 4th periods timer for setting. The setting method are same as 1st period timer.

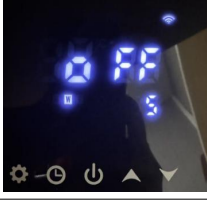

Press  to exit the timer settings.







5.9.2. Disinfect timer function

	<p>Press  some times until to show the “W” icon. Only display “W” can enter timer function setting.</p>	
<p>Long press  to enter the interface of 1st period DHW timer's Monday with “W” and “HW” first.</p>		<p>/</p>
<p>Long press  twice to enter to Disinfect timer's Monday setting with “W” and “Disinfect icon”.</p>		<p>/</p>
	<p>Press  to enter the setting, and press  to set Monday ON/OFF.</p> <p>If don't need to modify Monday default settings, press  to enter Tuesday setting.</p>	
<p>Press  to enter the setting, and press  to set Tuesday ON/OFF.</p>		<p>Press  to enter the setting, and press  to set Wednesday ON/OFF.</p>
<p>If don't need to modify Tuesday default settings, press  to enter Wednesday setting.</p>	<p>If don't need to modify Wednesday default settings, press  to enter Thursday setting.</p>	<p>If don't need to modify Wednesday default settings, press  to enter Thursday setting.</p>
	<p>Press  to enter the setting, and press  to set Thursday ON/OFF.</p> <p>If don't need to modify Thursday default settings, press  to enter Friday setting.</p>	

<p>Press  to enter the setting, and press  to set Friday ON/OFF.</p>		<p>Press  to enter the setting, and press  to set Saturday ON/OFF.</p>
<p>If don't need to modify Friday default settings, press  to enter Saturday setting.</p>	<p>Press  to enter the setting, and press  to set Sunday ON/OFF.</p>	<p>If don't need to modify Saturday default settings, press  to enter Sunday setting.</p>
	<p>If don't need to modify Monday-Sunday default settings, press  to set ON/OFF for Disinfect timer.</p>	 1 ON =Disinfect timer ON 1 OF =Disinfect timer OFF
<p>If don't need to modify Disinfect timer ON/OFF default settings, press  to timer start/stop time period.</p>	<p>Press  to enter start/stop time period setting interface and press  to set the operating time.</p>	<p>Press  to exit the Disinfect timer settings.</p>





Note: The disinfect timer is set to start at 02:00 AM every Tuesday by factory default.





















5.9.3. Holiday timer function

	<p>Press  some times until to show the "W" icon. Only display "W" can enter timer function setting.</p>	
<p>Long press  to enter the interface of 1st period DHW timer's Monday with "W" and "HW" first.</p>		<p>/</p>
<p>Long press  thrice to enter the interface of Holiday timer start year with "Y" and "Holiday".</p>		<p>/</p>









<p>Press  to enter the year setting, and press  to set the starting year.</p>		<p>Press  to enter the month setting, and press  to set the starting month.</p>
<p>If not need to set the year, press  to set holiday timer starting month.</p>		<p>If not need to set the month, press  to set holiday timer starting day.</p>
	<p>Press  to enter the starting day setting, and press  to set starting day.</p>	
<p>Press  to enter ending year setting, and press  to set ending year.</p>		<p>Press  to enter the ending month setting, and press  to set ending month.</p>
<p>If not need to set ending year, please press  to set holiday ending month.</p>		<p>If not need to set ending month, please press  to set holiday ending day.</p>
	<p>Press  to exit the Holiday timer settings.</p>	

5.9.4. Mute timer function

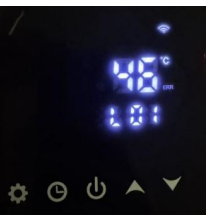
	<p>Press  some times until to show the "W" icon. Only display "W" can enter timer function setting.</p>	
<p>Long press  to enter the interface of 1st period DHW timer's Monday with "W" and "HW" first.</p>		<p>Long press  quintic to enter the interface of 1st Mute timer's Monday with only "W" and without any other function indicated icon.</p>
	<p>Press  to enter the Monday setting, and press  to set Monday ON/OFF.</p> <p>If don't need to modify Monday default settings, press  to enter Tuesday setting.</p>	
<p>Press  to enter the Tuesday setting, and press  to set Tuesday ON/OFF.</p>		<p>Press  to enter the Wednesday setting, and press  to set Wednesday ON/OFF.</p>
<p>If don't need to modify Monday default settings, press  to enter Wednesday setting.</p>	<p>If don't need to modify Wednesday default settings, press  to enter Thursday setting.</p>	<p>If don't need to modify Wednesday default settings, press  to enter Thursday setting.</p>
	<p>Press  to enter the Thursday setting, and press  to set Thursday ON/OFF.</p> <p>If don't need to modify Thursday default settings, press  to enter Friday setting.</p>	

<p>Press  to enter the Friday setting, and press  to set Friday ON/OFF.</p>		<p>Press  to enter the Saturday setting, and press  to set Saturday ON/OFF.</p>
<p>If don't need to modify Friday default settings, press  to enter Saturday setting.</p>		<p>If don't need to modify Saturday default settings, press  to enter Sunday setting.</p>
	<p>Press  to enter the Sunday setting, and press  to set Sunday ON/OFF.</p>	
	<p>If don't need to modify Monday-Sunday default settings, press  to set ON/OFF for Mute 1st timer.</p>	
<p>1 ON = 1st Mute timer ON 1 OF = 1st Mute timer OFF</p>	 	<p>1o = 1st period timer ON Hour setting 1o = 1st period timer ON Minute setting 1F = 1st period timer OFF Hour setting 1F = 1st period timer OFF Minute setting</p>
<p>If don't need to modify 1st Mute timer ON/OFF default settings, press  to set 1st Mute timer start/stop time period.</p>	 	
	<p>Mute function has 2 periods timers. While setting the 1st timer, press  to switch to 2nd periods timer for setting. The setting method are same as 1st period timer.</p>	
<p>Press  to exit the Mute timer settings.</p>		

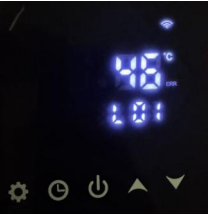
5.10 Error information

	<p>If there is a malfunction, the main interface will display the ERROR icon.</p>	<p>Press  for 3 seconds to check Unit Status information .</p>
	<p>Press  for 3 seconds again to check Unit Error information .</p>	
	<p>If there isn't any malfunction, the main interface will not display the ERROR icon.</p>	<p>Press  for 3 seconds to check Unit Status information</p>
	<p>Press  for 3 seconds to check Unit Error history.</p>	

Code	Description	Fault analysis	Check method	Solution
EEC	Communication failure between main control board and the wire controller	1. The communication line is not connected properly. 2. The communication port of controller is damaged. 3. The communication port of the main board is damaged.	Check the connection wires	Replace the communication cable and connect it properly. If that doesn't work, replace new wire controller. If it still doesn't work, replace the main board.
E01	DHW tank Temp. sensor failure	The temperature sensor has temperature deviation or open circuit.	Check the resistance of the temperature sensor or whether the temperature sensor is disconnected.	Replace new temperature sensor or reconnect the wire.
E02	Heating tank Temp. sensor failure			
E03	Return water Temp. sensor failure			
E04	Outlet water Temp. sensor failure			
E05	Exhaust Temp. sensor failure			
E06	Return gas Temp. sensor failure			
E07	Coil Temp. sensor failure			
E08	Ambient Temp. sensor failure			
E09	Return air Temp. sensor failure			
E10	Room 1 Temp. sensor failure			
P17	Ambient temperature ultralow protection	Beyond the unit operating temperature range	If the ambient temperature is not consistent with the current displayed value, please check if the sensor is damaged.	If the Temp. sensor value is normal, no action is required. The unit will automatically switch to electric heater for heating.
P18	Ambient temperature overheat protection	Beyond the unit operating temperature range	If the ambient temperature is not consistent with the current displayed value, please check if the sensor is damaged.	If the Temp. sensor value is normal, no action is required. The unit will automatically switch to electric heater to heat.
P01	High pressure switch protection	1. Water flow is too small; 2. High-pressure switch failure; 3. Refrigeration system is blocked; 4. EEV is locked.	1. Check whether there is water shortage or insufficient water pump flow; 2. Check whether the high-pressure switch is disconnected due to heat pump are turned off; 3. Check whether the refrigeration system is blocked; 4. Check whether the EEV makes a resetting sound when the heat pump is in shutdown mode and the power is turned on or off.	1. Refill water or replace a water pump with a larger flow rate or add a booster pump; 2. Replace new high-pressure switch; 3. Replace new filter; 4. Replace new EEV.

P02	Low pressure switch protection	1. Lack of refrigerant; 2. Refrigeration system is blocked; 3. Exceeding the system working range;	1. Check if the refrigerant system is leaking; 2. Check if the filter is clogged; 3. Check if the ambient temperature or outlet water temperature exceeds the limit.	1. Repair the leakage and refill the refrigerant. 2. Replace new filter; 3. If the system exceeds the operating limit, shut down the unit;
P03	Air exhaust temperature overheat protection	1.Lack of refrigerant; 2.Exhaust temperature sensor failure.	1. Check if the refrigerant system is leaking; 2. Check whether the exhaust temperature sensor is faulty.	1. Repair the leakage and refill the refrigerant. 2. Replace new exhaust temperature sensor.
P04	Water flow switch protection	1. The system lacks water. 2. The water flow switch failure.	1. Check whether the water supply valve is closed or the water supply is cut off; 2. Check whether the water flow switch is blocked or interrupted	1. Turn on the valve; 2. Replace new one water flow switch;
P05	Secondary water flow switch protection	3. The water system is blocked. 4. The temperature difference between inlet water and outlet water is too big.	3. Check whether the Y-filter is clogged.	3. Clean or replace new filter screen.
P07	Overheated outlet water temperature protection	Self-recovery	Self-recovery	Self-recovery
P08	Overlarge temperature difference between inlet and outlet water protection	1. The system lacks water. 2. The water flow switch failure. 3. The water system is blocked. 4. The temperature difference between inlet water and outlet water is too big.	1. Check whether the water supply valve is closed or the water supply is cut off; 2. Check whether the water flow switch is blocked or interrupted 3. Check whether the Y-filter is clogged.	1. Turn on the valve; 2. Replace new one water flow switch; 3. Clean or replace new filter screen.
P09	DC fan 1 failure	1. The connection cable between the fan board and the main board is damaged. 2. The fan board is damaged. 3. The fan wire is not plugged into the circuit board. 4. The fan is broken.	1. Check if the connection cable between the fan board and the main board has come loose. 2. Check if the lights on the fan board are still on.	1. Replace the new connection wire. 2. Replace the fan board. 3. Insert the fan wire onto the circuit board. 4. Replace the new fan.
P11	Defrosting and anti-freezing protection	When the outlet water temperature during defrosting drops below 5 degrees, the defrosting process will be forcibly stopped.	Self-recovery	No need to handle
F01	High pressure switch protection three times	1. Water flow is too small; 2. High-pressure switch failure; 3. Refrigeration system is blocked; 4. EEV is locked.	1. Check whether there is water shortage or insufficient water pump flow; 2. Check whether the high-pressure switch is disconnected due to heat pump are turned off; 3. Check whether the refrigeration system is blocked; 4. Check whether the EEV makes a resetting sound when the heat pump is in shutdown mode and the power is turned on or off.	1. Refill water or replace a water pump with a larger flow rate or add a booster pump; 2. Replace new high-pressure switch; 3. Replace new filter; 4. Replace new EEV.

F02	Low pressure switch protection three times	<ol style="list-style-type: none"> 1. Lack of refrigerant; 2. Refrigeration system is blocked; 3. Exceeding the system working range; 	<ol style="list-style-type: none"> 1. Check if the refrigerant system is leaking; 2. Check if the filter is clogged; 3. Check if the ambient temperature or outlet water temperature exceeds the limit. 	<ol style="list-style-type: none"> 1. Repair the leakage and refill the refrigerant. 2. Replace new filter; 3. If the system exceeds the operating limit, shut down the unit;
F03	Air exhaust temperature overheat protection three times	<ol style="list-style-type: none"> 1. Lack of refrigerant; 2. Exhaust temperature sensor failure. 	<ol style="list-style-type: none"> 1. Check if the refrigerant system is leaking; 2. Check whether the exhaust temperature sensor is faulty. 	<ol style="list-style-type: none"> 1. Repair the leakage and refill the refrigerant. 2. Replace new exhaust temperature sensor.
F04	Water flow switch protection three times	<ol style="list-style-type: none"> 1. The system lacks water. 2. The water flow switch failure. 3. The water system is blocked. 	<ol style="list-style-type: none"> 1. Check whether the water supply valve is closed or the water supply is cut off; 2. Check whether the water flow switch is blocked or interrupted 	<ol style="list-style-type: none"> 1. Turn on the valve; 2. Replace new one water flow switch; 3. Clean or replace new filter screen.
F05	Secondary water flow switch protection three times	<ol style="list-style-type: none"> 4. The temperature difference between inlet water and outlet water is too big. 	<ol style="list-style-type: none"> 3. Check whether the Y-filter is clogged. 	
F07	Overheated outlet water temperature protection three times	Tw and Tc sensor may become loose, resulting in the inability to sense the correct water tank temperature.	Check the reason why the outlet water has reached the target temperature but neither the hot water nor the heating has not reached the desired temperature.	
F08	Overlarge temperature difference between inlet and outlet water protection three times	<ol style="list-style-type: none"> 1. The system lacks water. 2. The water flow switch failure. 3. The water system is blocked. 4. The temperature difference between inlet water and outlet water is too big. 	<ol style="list-style-type: none"> 1. Check whether the water supply valve is closed or the water supply is cut off; 2. Check whether the water flow switch is blocked or interrupted 3. Check whether the Y-filter is clogged. 	<ol style="list-style-type: none"> 1. Turn on the valve; 2. Replace new one water flow switch; 3. Clean or replace new filter screen.
F09	DC fan 1 failure three times	<ol style="list-style-type: none"> 1. The connection cable between the fan board and the main board is damaged. 2. The fan board is damaged. 3. The fan wire is not plugged into the circuit board. 4. The fan is broken. 	<ol style="list-style-type: none"> 1. Check if the connection cable between the fan board and the main board has come loose. 2. Check if the lights on the fan board are still on. 	<ol style="list-style-type: none"> 1. Replace the new connection wire. 2. Replace the fan board. 3. Insert the fan wire onto the circuit board. 4. Replace the new fan.
F11	Defrosting and anti-freezing protection three times	When the outlet water temperature during defrosting drops below 5 degrees, the defrosting process will be forcibly stopped.	To prevent damage to the heat exchanger caused by defrosting when the outlet water temperature is below 5 degrees, please power off the unit and restart.	First heat the water.

6. Device Networking

6.1 First, please search and download the "MaxT" software in the Apple App Store or the Google Play Store.

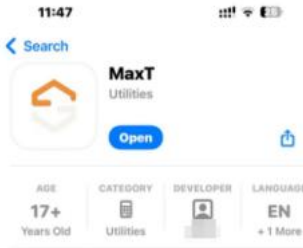

6.2 The HP installer registers on the IOT platform and provides the account and password. (Due to privacy regulations, allowing self-registration of accounts carries the risk of unauthorized individuals privately registering and binding devices. Therefore, self-registration is currently not supported. Users will need to receive their account credentials from a dealer and then change the password themselves.)

Device Networking Configuration(WIFI version)

(1) Preparation: The mobile phone used for operation should first connect to their desired WIFI and turn on the phone's Bluetooth function.

(2) After powering on the wireless controller, wait for it to enter the main interface. If the WiFi icon in the upper-right corner remains off (indicating unpaired status), proceed with Bluetooth network configuration directly via the APP.

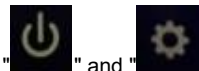

(3) If the WiFi icon keep on lighting, please long press and hold the "power" and "settings" icons for 1 second. Wait until the WiFi icon blinks rapidly for several seconds and then turns off, indicating the WiFi connection has been terminated. Then proceed with Bluetooth pairing via the APP.

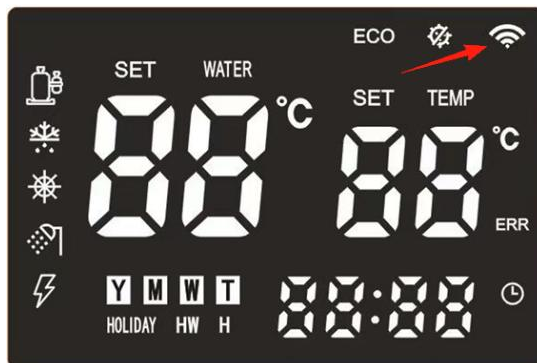

(4) Open the "MaxT" APP, go to 'More' and select 'Bluetooth provisioning' (as shown in Figure 1).

(5) Click the 'Add' button on the right side of the device detecting interface (as shown in Figure 2). Enter the WIFI account and password (as shown in Figure 3), and finally complete the network configuration (as shown in Figure 4).

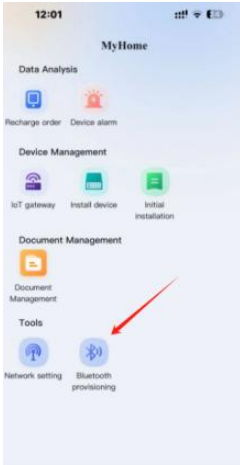

Figure 1

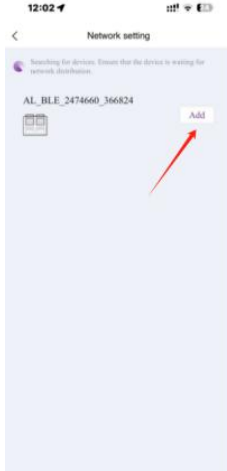

Figure 2



Figure 3

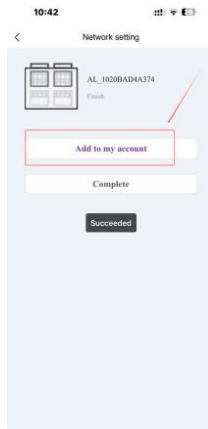

Figure 4

(6) After completion, the account will be automatically bound to the device.

7.App Operation

7.1 Power ON/OFF



7.2 DHW Temperature Setting

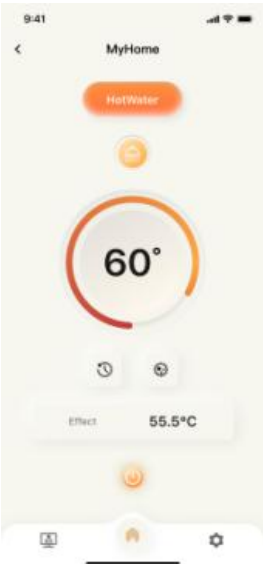



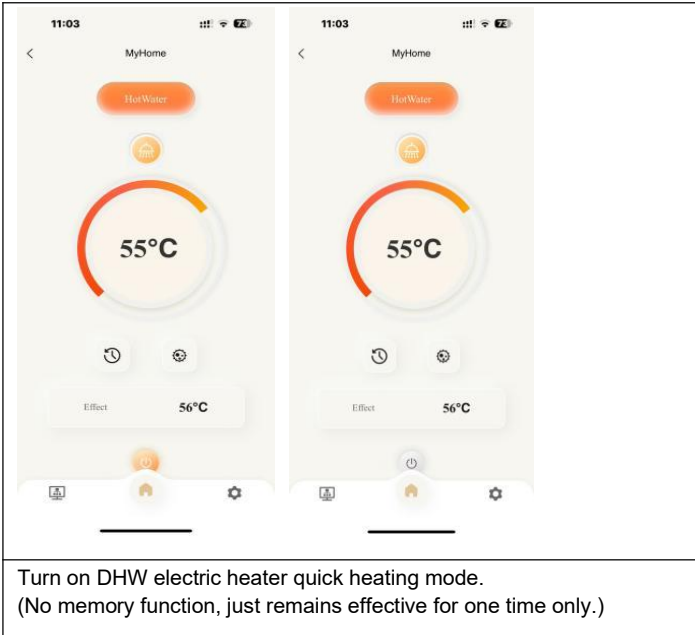

7.3 Electric heater quick heating mode



7.4 Timer setting



	
<p>Press  to enter disinfect function timer setting on the DHW setting interface</p>	<p>Press  to enter DHW timer setting on the DHW setting interface (4 periods)</p>

7.5 Fault Query

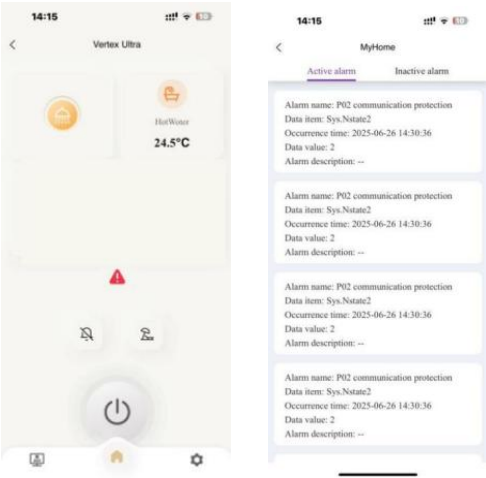

8.Maintenance

8.1 Maintenance

- Check the connection between power supply plug, socket and ground wiring regularly.
- In some cold area (below 0°C), if the unit will be stopped for a long time, all the water should be released in case of freezing of inner tank and damage of boost electric heater.
- It is recommended to clean the inner tank and boost E-heater every half year to keep an efficient performance. Check the anode rod every half year and change it, if it has been used out. For more details, please contact the supplier or the after-sale service.
- It is recommended to set a lower temperature to decrease the heat release, prevent scale and save energy if the outlet water volume is sufficient.
- Clean the air filter every month in case of any inefficiency on the heating performance.
- Before shutting off the heat pump the system off for a long time, please:

Shut off the power supply;

Release all the water in the water tank and the pipeline. Close all the valves;

- Check the inner components regularly.

8.2 How to change the anode rod

- Turn off the power supply, and turn off the water inlet valve.
- Open hot water tap, and decrease the pressure of the inner tank.
- Open the drainage valve, and drain out the water, until there are no water flow out.
- Take out the anode rod.
- Replace it with a new one, and make sure effective sealed.
- Open cold water inlet tap until water flows out from outlet tap then close water outlet tap.
- Power on and restart the unit.

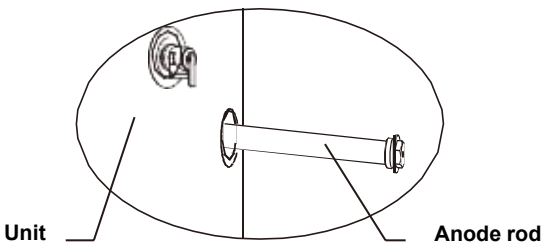

8.3 Recommended regular maintenance table

Item	Checking content	Check frequency	Action
1	Anode rod	Every 6 months	Replace it if it has been used out.
2	Inner tank	Every 6 months	Clean the tank.
3	Boost E-heater	Every 6 months	Clean E-heater.
4	PTR valve (If the unit with PTR valve)	Every 1 year	Operate the handle of the PTR valve to ensure that water can be flowed out.
		If water does not flow freely when operating the handle, replace PTR valve with a new one.	

